



PRESSURE SWITCHES
PRESSURE DIFFERENCE SWITCHES
VACUUM SWITCHES
From 1.5 mbar to 600 bar

MT High Range Compound Switches

CATALOGUE

Certificate No.: FM72815



Kaustubha Udyog AN ISO9001:2008 COMPANY

S. No. 36/1/1, Sinhgad Road, Vadgaon Khurd,
Near Lokmat Press, Pune 411 041 INDIA
Tel. : +91-(0) 20-24393577 / 24393877
Telefax: +91-(0) 20-24393577 / 25460486
Email : pressure@vsnl.com

Website : <http://www.orion-instruments.com>

MT HIGH RANGE COMPOUND



PRESSURE CAPSULE DETAILS

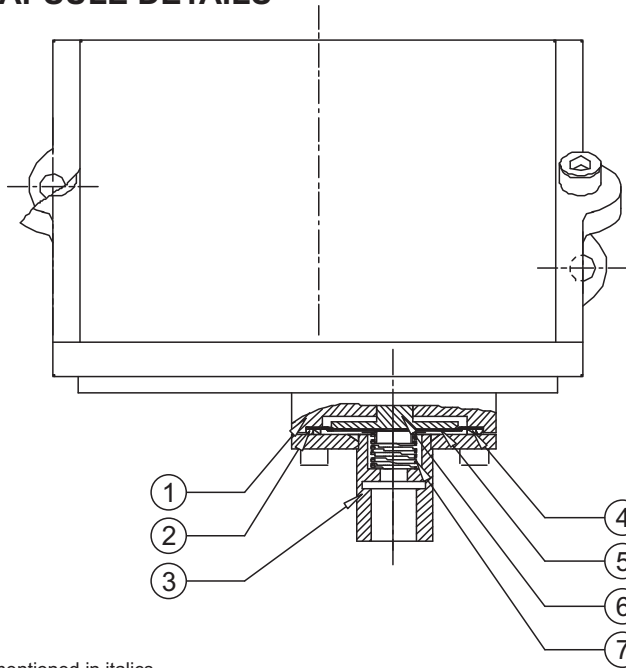

No. Description

1. Disc
2. 'O' ring (Teflon®)
3. Pressure Housing
4. Steel Ring (SS316)
5. Diaphragm (Teflon®)
6. Plunger
7. Spring (SS316)

Note : *wetted parts* are mentioned in italics.

INSTALLATION DRAWING

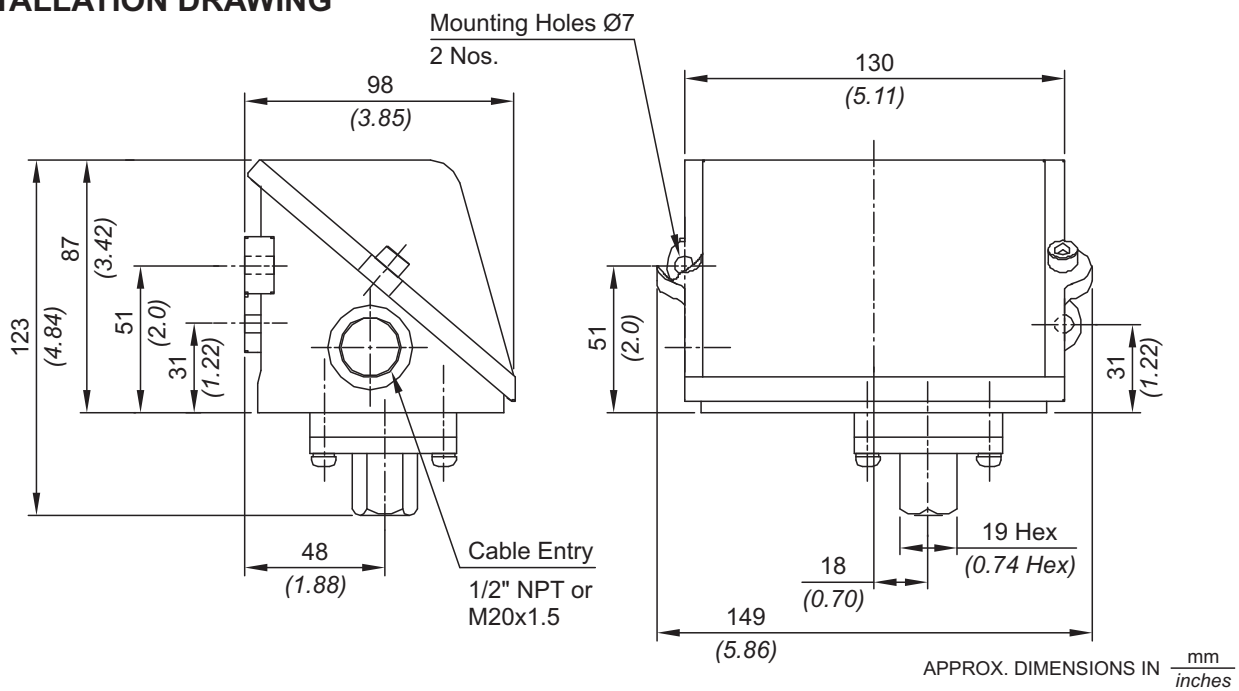

RANGE SELECTION TABLE

Range Code	Range bar (psi)	Differential* bar (psi)	Maximum Working Pressure bar (psi)
		Approximate Maximum for "A1" microswitch	
C01	-1 to 1.0 (-14.50 - 14.50)	0.2 (2.90)	12 (174.05)
C03	-1 to 2.6 (-14.50 - 37.71)	0.6 (8.70)	12 (174.05)
C04	-1 to 3.6 (-14.50 - 52.26)	0.8 (11.60)	12 (174.05)

* Minimum differential increases with setpoint (Graphs available on request)

* Differentials of microswitches A2 through A9 will vary. Differentials for A7 are typically twice that for A1 microswitch. Please indicate specifically the differential value in enquiry/order, when it is critical in your application.

HOW TO ORDER INDUSTRIAL HIGH RANGE COMPOUND SWITCHES

Group 1	Group 2	Group 3	Group 4	Group 5	Group 6	Group 7	Group 8
Non standard allocation	Gas Group Classification	Cable Entry Size	Switch Type	Range Code (values in bar)	Microswitch Type	Pressure Port Material / Size	Diaphragm
<input type="checkbox"/> Reserved for non-standard options not covered in catalogue. Will be given by manufacturer, only after agreement of supply details with customer.	MT = Industrial pressure switch with diecast Aluminium enclosure to IP66 as per IS/IEC 60529	1 = Al. head 1/2" NPT threads 3 = Al. head M20 X 1.5 threads	CF2 = pressure switch, fixed differential with scale in bar CF3 = pressure switch, fixed differential with scale in psi	C01 = (-1 to 1.0) C03 = (-1 to 2.6) C04 = (-1 to 3.6)	A1 = General purpose microswitch rated at 15 A; 250 VAC A2 = Hermetically sealed for corrosive environments A3 = gold plated contacts for low voltage applications A4 = DPDT configuration A5 = for high DC ratings A6 = elements with adjustable deadband A7 = 2SPDT switching elements A9 = General purpose microswitch rated at 5 A; 250 VAC	S1 = SS316 / 1/4" BSP(F) S2 = SS316 / 1/4" NPT(F)	0 = Neoprene 1 = Teflon

eg. A industrial switch with 1/2" NPT cable entry in aluminium housing as 1SPDT pressure switch, having -1 bar to +1 bar pressure range, with 15 Amp. microswitch, SS316 pressure housing with 1/4" BSP port size & Neoprene diaphragm shall be specified by

Group 1	Group 2	Group 3	Group 4	Group 5	Group 6	Group 7	Group 8
<input type="checkbox"/>	MT	1	CF2	C01	A1	S1	0

Please specify full model number to avoid ambiguity. If only the first two groups are specified while ordering, uncalibrated switches with standard wetted parts and enclosures will be supplied.