



**PRESSURE SWITCHES
PRESSURE DIFFERENCE SWITCHES
VACUUM SWITCHES**
From 1.5 mbar to 600 bar

MT Low Range Pressure Difference Switches CATALOGUE

Certificate No.: FM72815



Kaustubha Udyog AN ISO9001:2008 COMPANY

S. No. 36/1/1, Sinhgad Road, Vadgaon Khurd,
Near Lokmat Press, Pune 411 041 INDIA
Tel. : +91-(0) 20-24393577 / 24393877
Telefax: +91-(0) 20-24393577 / 25460486
Email : pressure@vsnl.com

Website : <http://www.orion-instruments.com>

MD/MT

LOW RANGE PRESSURE DIFFERENCE SWITCHES



MD



PRESSURE CAPSULE DETAILS

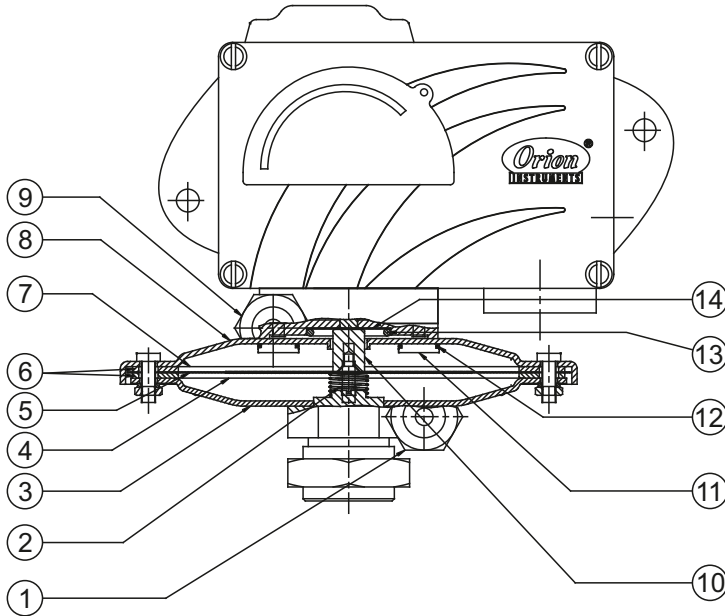

No. Description

1. High Pressure Port (SS)*
2. Support Spring (SS)
3. Bottom Flange (SS)
4. Support Plate (Aluminium)
5. Diaphragm (Neoprene)
6. Gasket (Nitrile)
7. Top Plate (Aluminium)
8. Top Flange (SS)*
9. Low Pressure Port (SS)
10. Transfer Pin (Al)
11. Top Flange Screw (SS)
12. O-Ring (Nitrile)
13. O-Ring (Nitrile)
14. Sealing Diaphragm (Nitrile)

Note : *wetted parts* are mentioned in italics.

*Pressure ports are brazed with flange

INSTALLATION DRAWING

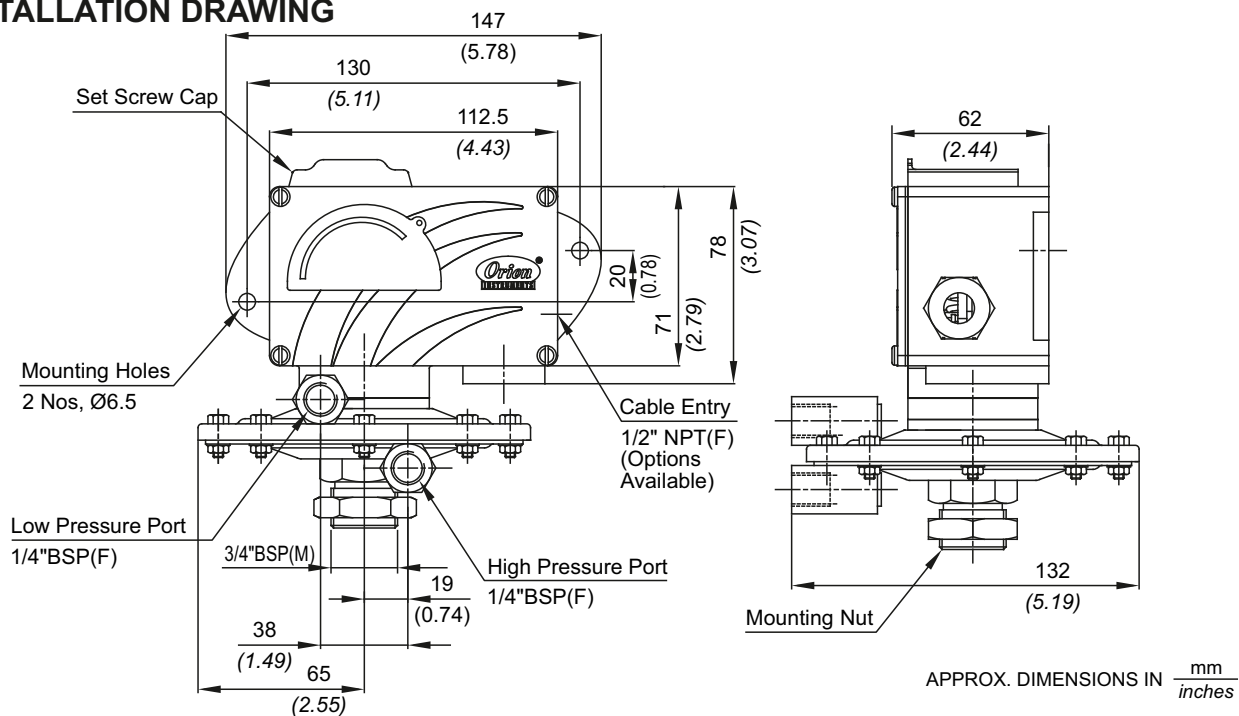

LOW RANGE PRESSURE DIFFERENCE SWITCHES

MD/MT



MT



PRESSURE CAPSULE DETAILS

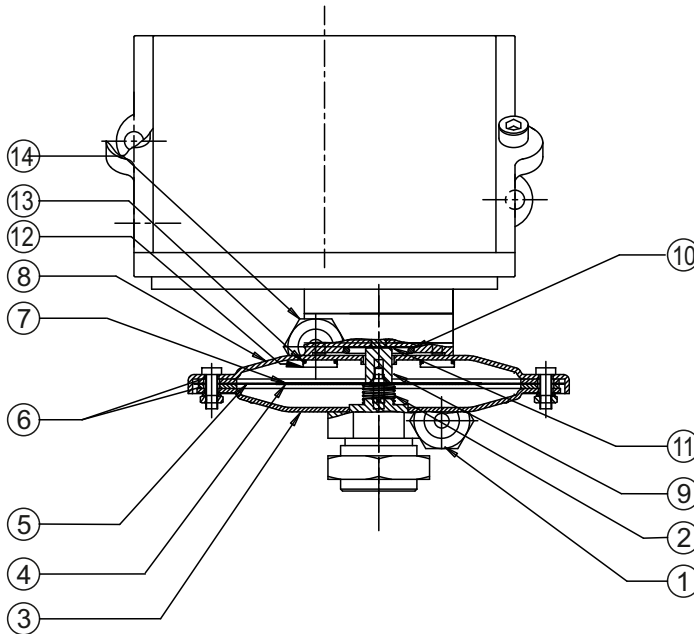

No. Description

1. High Pressure Port (SS)*
2. Support Spring (SS)
3. Bottom Flange (SS)
4. Support Plate (Aluminium)
5. Diaphragm (Neoprene)
6. Gasket (Nitrile)
7. Top Plate (Aluminium)
8. Top Flange (SS)*
9. Transfer Pin (Aluminium)
10. O-Ring (Nitrile)
11. Sealing Diaphragm (Nitrile)
12. Top Flange Screw (SS)
13. Sealing O-Ring (Nitrile)
14. Low Pressure Port (SS)*

Note : *wetted parts* are mentioned in italics.

*Pressure ports are brazed with flange

INSTALLATION DRAWING

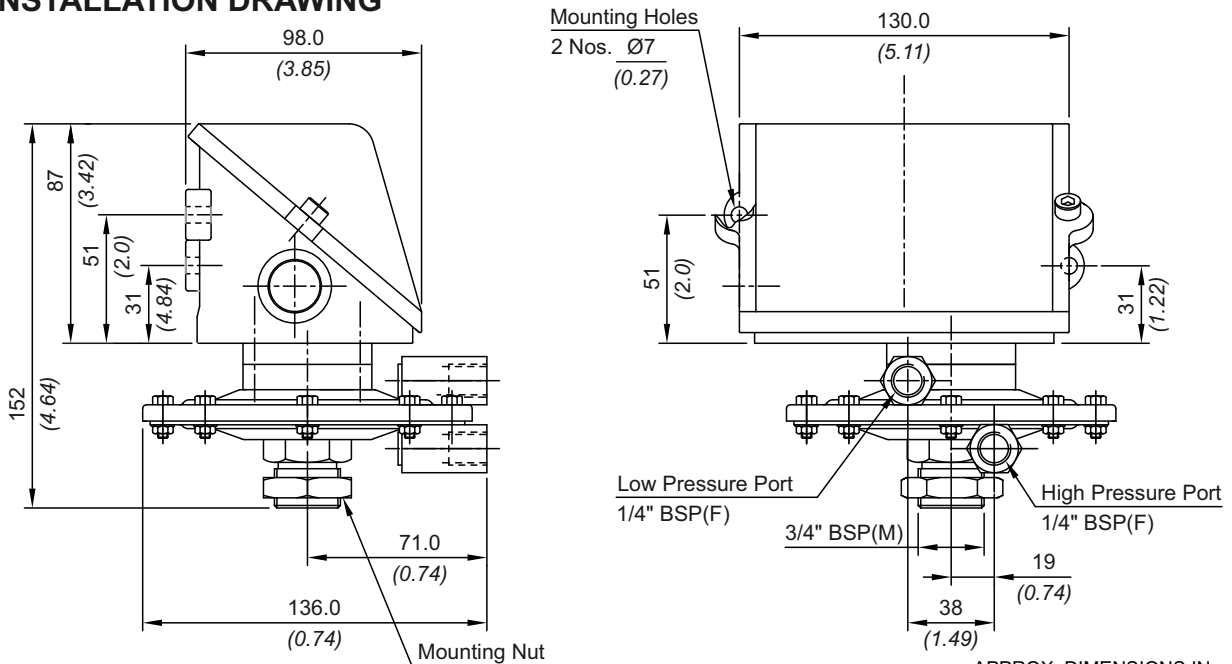

APPROX. DIMENSIONS IN $\frac{\text{mm}}{\text{inches}}$

MD/MT LOW RANGE PRESSURE DIFFERENCE SWITCHES

RANGE SELECTION TABLE

Range Code	Range mbar ("wc)	Differential* mbar (" wc)	Maximum Working Pressure bar (psi)
		Approximate Maximum for "A1" microswitch	
L02	3 - 15 (1.205 - 6.02)	3 (1.204)	2 (29.00)
L03	5 - 25 (2.007 - 10.037)	5 (2.007)	2 (29.00)
L05	10 - 50 (4.015 - 20.073)	5 (2.007)	2 (29.00)
L10	10 - 100 (4.015 - 40.146)	10 (4.015)	2 (29.00)
L15	10 - 150 (4.015 - 60.22)	15 (6.027)	2 (29.00)
L25	20 - 250 (8.03 - 100.36)	20 (8.037)	2 (29.00)
L35	50 - 350 (20.073 - 140.51)	35 (14.05)	2 (29.00)

Note:

1. The minimum differential increases with the setpoint. The differential values mentioned in the above table are approximate maximum for FSR. The differential value will vary according to the pressure range selected and microswitch type. For actual values of differential please contact sales office.

2. When using 2SPDT switching arrangement, both microswitches may not actuate and/or deactuate at the same point. A small stage gap, normally upto +/- 5% FSR (depending on range code) may be observed. The On-Off differential (hysteresis) typically tends to be atleast double of those published for 1SPDT pressure switches.

If actuation and/or deactuation at same point is critical part of operation, then it can be achieved by using a separate DPDT relay. This relay will need a separate power supply for it's coil.

LOW RANGE PRESSURE DIFFERENCE SWITCHES

MD/MT

HOW TO ORDER INDUSTRIAL LOW RANGE PRESSURE DIFFERENCE SWITCHES

Group 1	Group 2	Group 3	Group 4	Group 5	Group 6	Group 7	Group 8
Non standard allocation	Model	Cable Entry Size	Switch Type	Range Code (values in mbar)	Microswitch Type	Pressure Port Material / Size	Diaphragm
<input type="checkbox"/> Reserved for non-standard options not covered in catalogue. Will be given by manufacturer, only after agreement of supply details with customer.	MD = Industrial pressure switch with IP66 rated enclosure as per IS/IEC 60529 MT = Industrial pressure switch with IP66 rated enclosure as per IS/IEC 60529	1 = Al. enclosure 1/2" NPT threads *2 = Al. enclosure 3/4" NPT threads 3 = Al. enclosure M20 X 1.5 threads 7 = SS enclosure, 1/2" NPT threads *8 = SS enclosure, 3/4" NPT threads 9 = SS enclosure, M20 X 1.5 threads	DF1 = pressure difference switch, fixed differential without scale DF2 = pressure difference switch, fixed differential with scale in mbar DF3 = pressure difference switch, fixed differential with scale in "Wc *DA1 = pressure difference switch, adjustable differential without scale *DA2 = pressure difference switch, adjustable differential with scale in mbar *DA3 = pressure difference switch, adjustable differential with scale in "Wc *Available with A6, A9 & B9 (in group 6) only	L02 = (1.5 - 15) L03 = (5 - 25) L05 = (10 - 50) L10 = (10 - 100) L15 = (10 - 150) L25 = (20 - 250) L35 = (50 - 350)	A1 = General purpose microswitch, rated at 15 A; 250 VAC *A6 = Adjustable deadband *A7 = 2SPDT switching elements *A8 = General purpose microswitch *A9 = General purpose microswitch *B7 = 2SPDT Switching Elements *B9 = 2SPDT Switching Elements for adjustable differential * For detailed specifications of microswitches, please refer note under Range Selection Table	S1 = SS316 / 1/4" BSP(F) S2 = SS316 / 1/4" NPT(F)	0 = Neoprene 1 = PTFE

eg. A low range pressure difference industrial switch, with 1/2" NPT cable entry in aluminium housing as 1SPDT pressure switch, fixed differential without scale, having 5 mbar to 25 mbar pressure range, with 15Amp. microswitch, SS316 pressure housing with 1/4" BSP port size & neoprene diaphragm shall be specified by

Group 1	Group 2	Group 3	Group 4	Group 5	Group 6	Group 7	Group 8
<input type="checkbox"/>	MD	1	DF1	L03	A1	S1	0

Please specify full model number to avoid ambiguity.