

MD HIGH RANGE BELLOWS SWITCHES

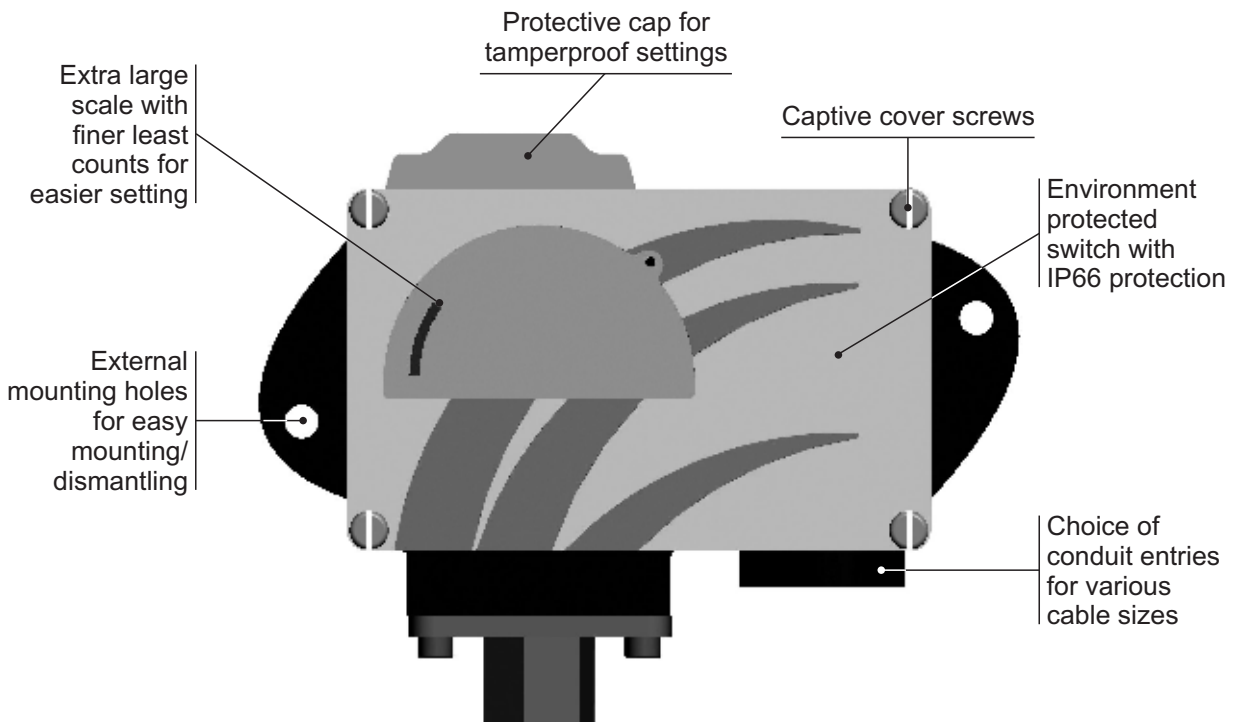
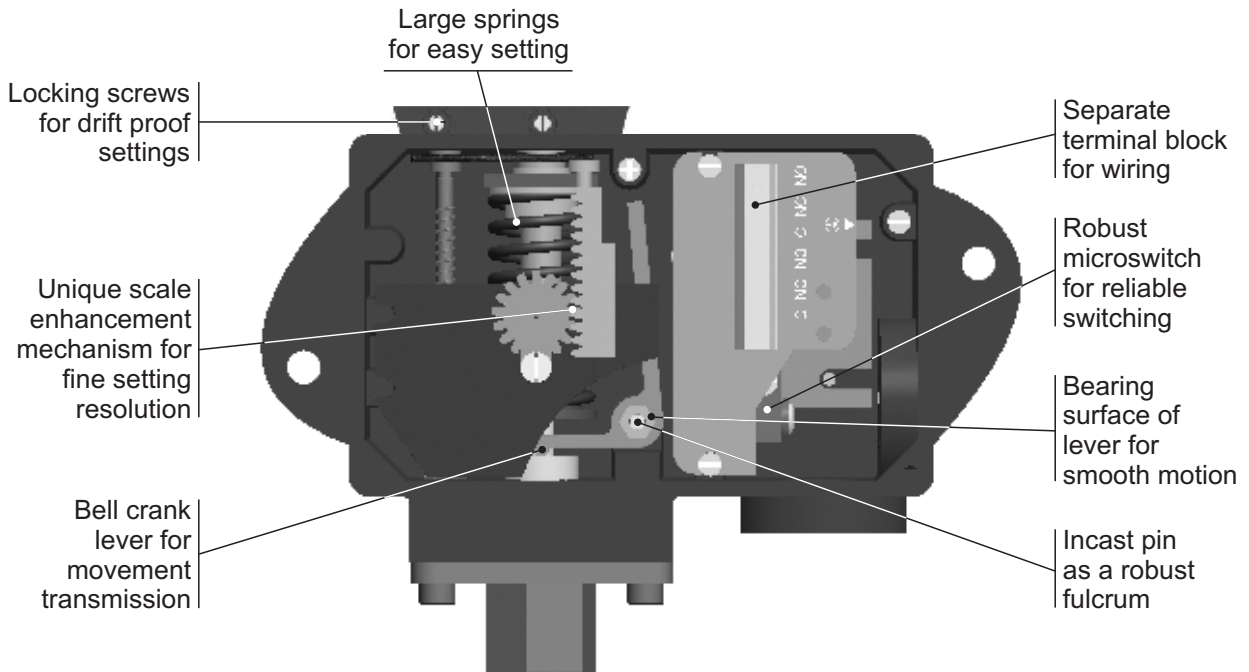

Approximate Weight : 0.700 Kg.

Some Applications : For cryogenic applications.

Electrical Connection :

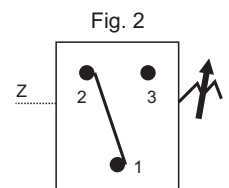

HIGH RANGE BELLOWS SWITCHES MD

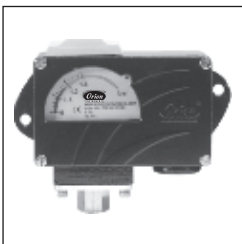

PRESSURE CAPSULE DETAILS

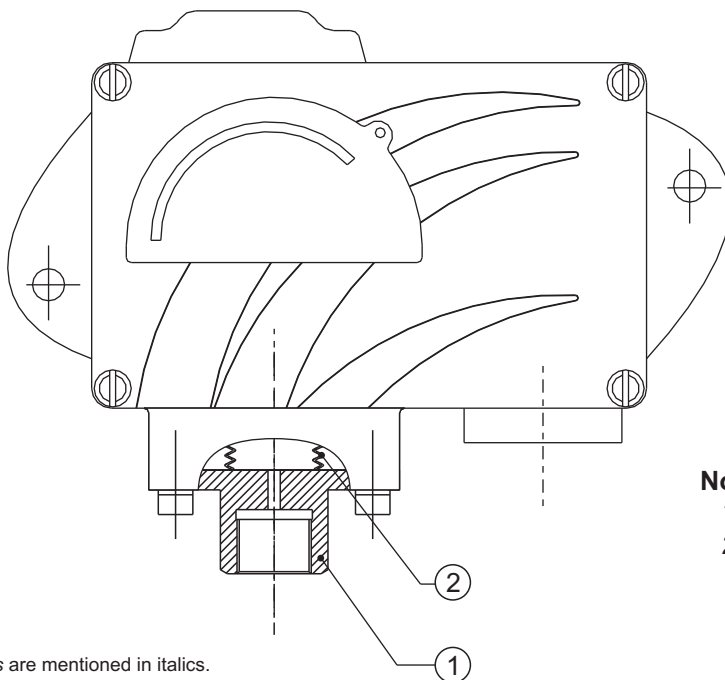

- No. Description**
 1. Pressure Port
 2. Metallic Bellow

Note : *wetted parts* are mentioned in italics.

INSTALLATION DRAWING

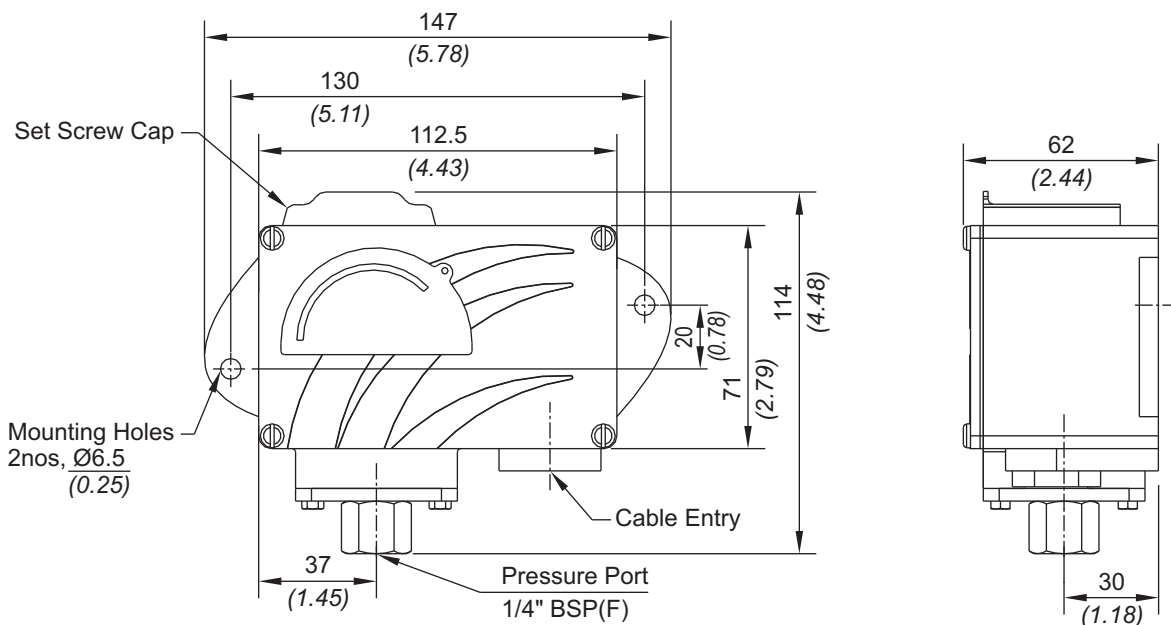

APPROX. DIMENSIONS IN $\frac{\text{mm}}{\text{inches}}$

MD HIGH RANGE BELLOWS SWITCHES

RANGE SELECTION TABLE

Range Code	Range bar (psi)	†Differential bar (psi)	Maximum Working Pressure bar (psi)
		Approximate Maximum for "A1" microswitch	
H01	0.1 - 1.0 (1.45 - 14.50)	0.10 (1.45)	12 (174.05)
H02	0.1 - 1.5 (1.45 - 21.76)	0.12 (1.74)	12 (174.05)
H03	0.2 - 2.6 (2.90 - 37.71)	0.17 (2.46)	12 (174.05)
H04	0.2 - 3.6 (2.90 - 52.21)	0.20 (2.90)	12 (174.05)
H07	0.5 - 7.0 (7.25 - 101.50)	0.40 (5.80)	12 (174.05)
H10	0.5 - 10.0 (7.25 - 145.03)	0.40 (5.80)	25 (362.6)
H15	1.0 - 15.0 (14.50 - 217.56)	0.80 (11.60)	25 (362.6)
H30	5.0 - 25.0 (72.52 - 362.59)	0.80 (11.60)	35 (507.63)
H4T	5.0 - 40.0 (72.52 - 580.15)	5.0 (72.52)	100 (1450.37)
H1H	10.0 - 100.0 (145.03 - 1450.37)	12 (174.05)	200 (2900.76)

† Minimum differential increases with setpoint, (Graphs available on request)

*** Note :**

Microswitches A2 through A9 can be supplied in some ranges and differentials will vary with microswitch used. Please contact sales office for details. Please check availability of adjustable differential with sales office.

HOW TO ORDER INDUSTRIAL HIGH RANGE BELLOWS PRESSURE SWITCHES

Group 1	Group 2	Group 3	Group 4	Group 5	Group 6	Group 7	Group 8
Non standard allocation	Model	Cable Entry Size	Switch Type	Range Code (values in bar)	Microswitch Type	Pressure Port Material / Size	Bellows
<input type="checkbox"/> Reserved for non-standard options not covered in catalogue. Will be given by manufacturer, only after agreement of supply details with customer.	MD = Industrial pressure switch with diecast Aluminium enclosure to IP66 as per IS2147	1 = 1/2" NPT threads 2 = 3/4" NPT threads 3 = M20 X 1.5 threads	PF1 = pressure switch, fixed differential without scale PF2 = pressure switch, fixed differential with scale in bar PF3 = pressure switch, fixed differential with scale in psi *PA1 = pressure switch, adjustable differential without scale *PA2 = pressure switch, adjustable differential with scale in bar *PA3 = pressure switch, adjustable differential with scale in psi *Available with A9 (in group 6) only	H01 = (0.1 - 1.0) H02 = (0.1 - 1.5) H03 = (0.2 - 2.6) H04 = (0.2 - 3.6) H07 = (0.5 - 7.0) H10 = (0.5 - 10.0) H15 = (1.0 - 15.0) H30 = (5.0 - 25.0) H4T = (5.0 - 40.0) H1H = (10.0 - 100.0)	A1 = General purpose microswitch rated at 15 A; 250 VAC *A2 = Hermetically sealed for corrosive environments *A3 = gold plated contacts for low voltage applications *A4 = DPDT configuration *A5 = for high DC ratings *A7 = 2SPDT switching elements *A9 = General purpose microswitch rated at 5 A; 250 VAC Please refer page no. 230 for more microswitch options * Please refer note under Range Selection Table	B1 = Bellows / 1/4" BSP(F) B2 = Bellows / 1/4" NPT(F)	2 = SS 316L

eg. A high range weatherproof bellows switch with 1/2" NPT cable entry in aluminium housing as 1SPDT pressure switch, fixed differential without scale, having 0.1 bar to 1 bar pressure range, with 15Amp. microswitch, SS316 pressure housing with 1/4" BSP port size & SS316L bellows shall be specified by

Group 1	Group 2	Group 3	Group 4	Group 5	Group 6	Group 7	Group 8
<input type="checkbox"/>	MD	1	PF1	H01	A1	B1	2

Please specify full model number to avoid ambiguity.